

PowerClean UV

HIGH SPECIFICATION UVC
STERILISATION UNIT

PERFECT FOR



FEATURES AND BENEFITS

- Modular design
- Easy incorporation into existing lines.
- Can be combined with other Secomak modules including the PowerWash and DryGuide.
- Guaranteed sterilisation
- Secomak work with the end user to ensure they get the LOG rate required.
- Easy/safe access
- Large gull wing doors provide unrestricted access whilst creating a minimal footprint.
- This system requires dry containers which keeps cleaning requirements to a minimum. The emitters are fully wash down compatible.
- The Secomak PowerClean UV uses UVC to sterilise surfaces of containers as they pass through on a conveyor.
- Up to 120,000 containers per hour
- Layout variants are dependant on the LOG reduction requirement of the end user, based on the Bacterium Bacillus Subtilis. See table below.

CLEANING UNIT

Number of modules	Length (mm)	LOG Reduction
1	1,500	2
2	3,000	4



Multiple PowerClean modules can be combined

PowerClean UV

DIMENSIONAL DRAWING

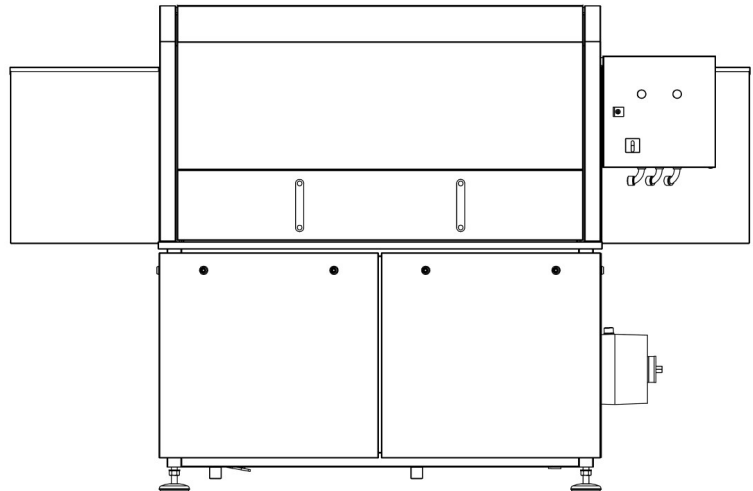
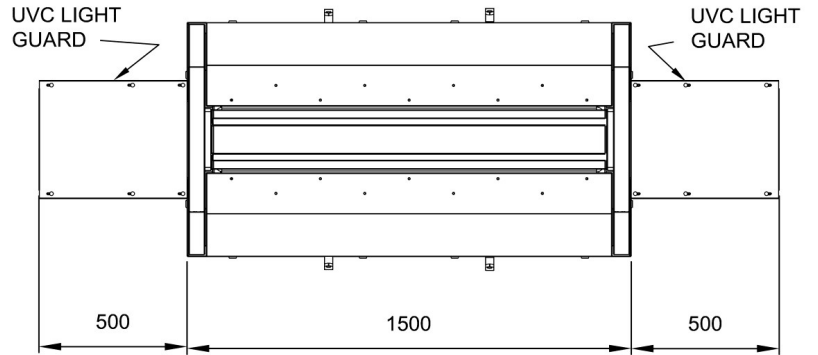
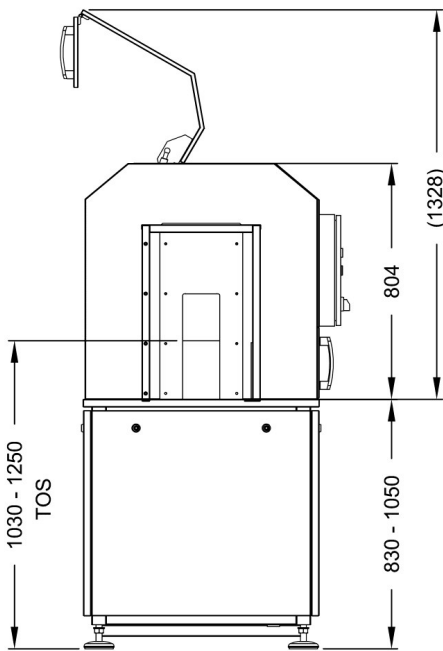

CLEANING UNIT

All dimensions in mm