

Model 587/2

HIGH-SPEED AIRFLOW FOR COOLING & HEATING

FEATURES AND BENEFITS

- Reliable Belt-Driven Performance
- Increase Pressure By Up To 98 mbar
- Extremely Energy Efficient
- High-Strength Industrial Design
- Compact Footprint For Easy Installation
- Very Low Maintenance



Product supplied may differ from image based on pressure requirements. Image represents Model 587 High Velocity Blower.

	587/2
Motor	5.5 kW
Weight	84 kg
Phase	3
Noise level*	90 dB(A)
Voltage	380 V - 480 V
Frequency	50 / 60 Hz
Run current	10.6 A

*Noise levels have been measured at a distance of 1m from the blower.

BLOWERS - HIGH VELOCITY

PERFORMANCE CURVE

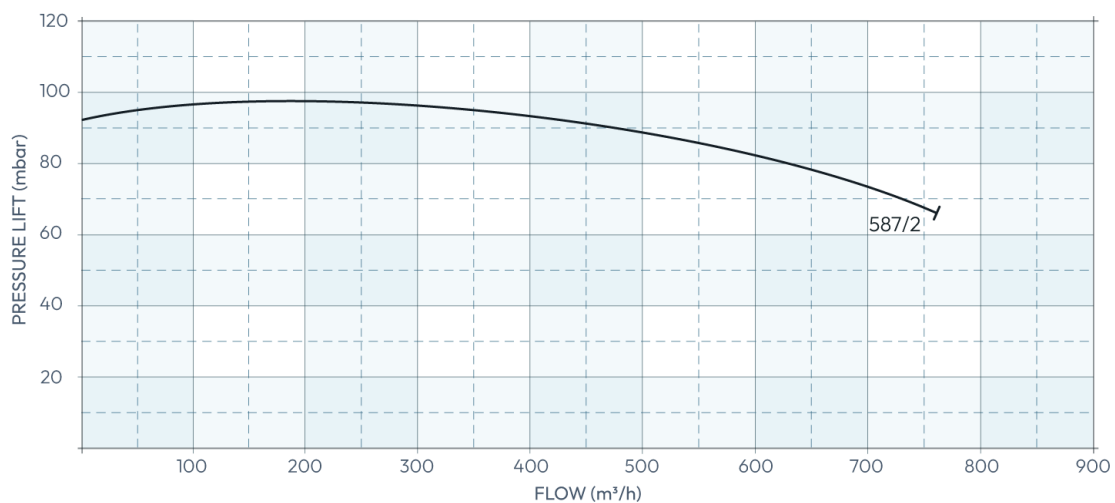

Model 587/2

DIMENSIONAL DRAWING

BLOWERS - HIGH VELOCITY

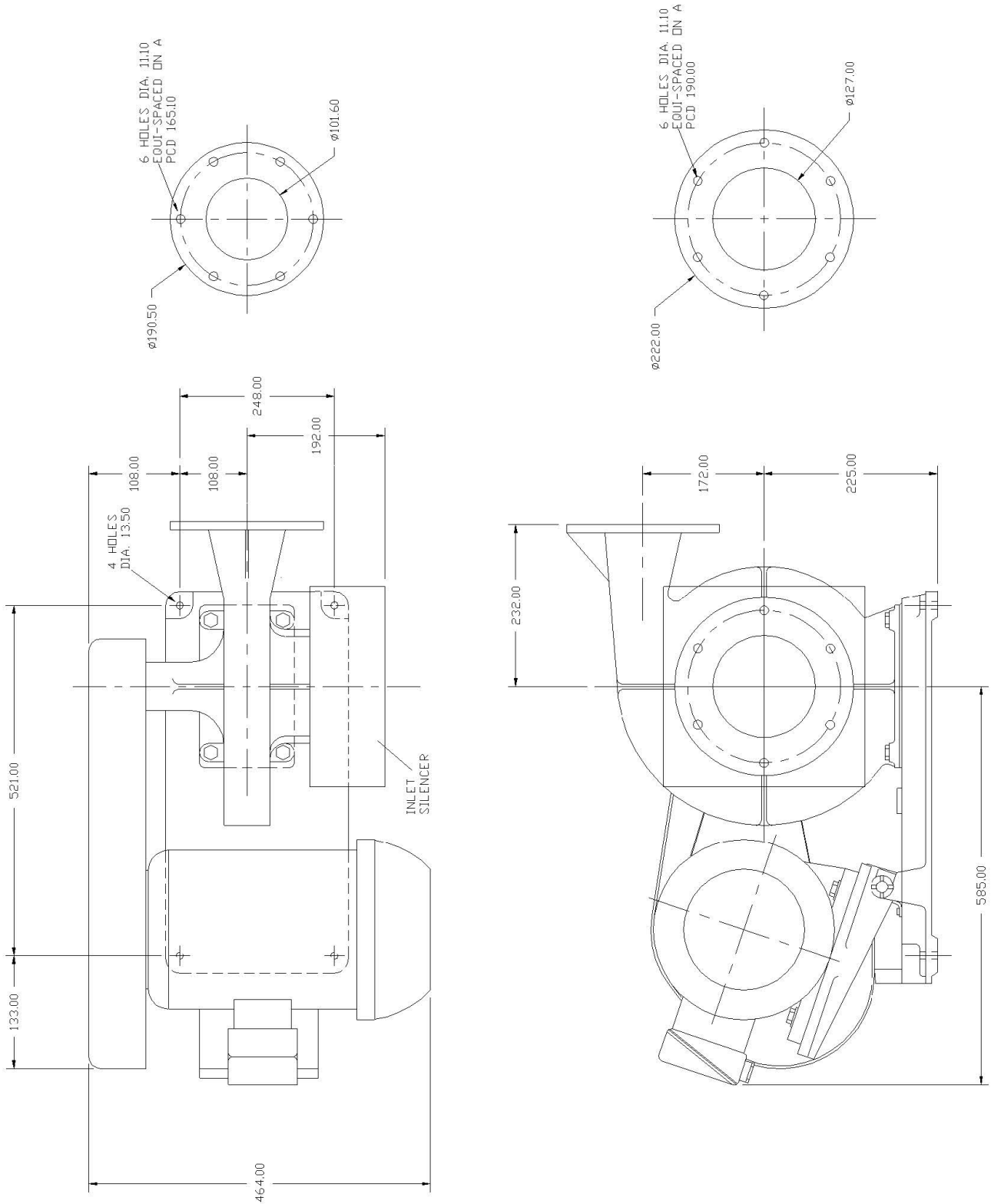

All dimensions in mm